

13310 / 41004 / 757610 / RRH13310

73-97 FORD
78-97 FORD BRONCO FULL SIZE
67-02 DODGE FULL SIZE

12/10/2007

GROSS LOAD CAPACITY WHEN USED AS A WEIGHT CARRYING HITCH: 6000 LBS. TRAILER WEIGHT & 600 LBS. TONGUE WEIGHT.
GROSS LOAD CAPACITY WHEN USED AS A WEIGHT DISTRIBUTION HITCH: 10000 LBS. TRAILER WEIGHT & 1000 LBS. TONGUE WEIGHT

*****DO NOT EXCEED VEHICLE MANUFACTURER'S RECOMMENDED TOWING CAPACITY.*****

Parts List			
ITEM	QTY	PART NUMBER	DESCRIPTION
1	6	HFN 1213	HEX FLANGE NUT
2	8	CM-SP1	.250 x 1.50 x 2.00" SQUARE HOLE SPACER
3	6	1/2-13 x 1 3/4	CARRIAGE BOLT

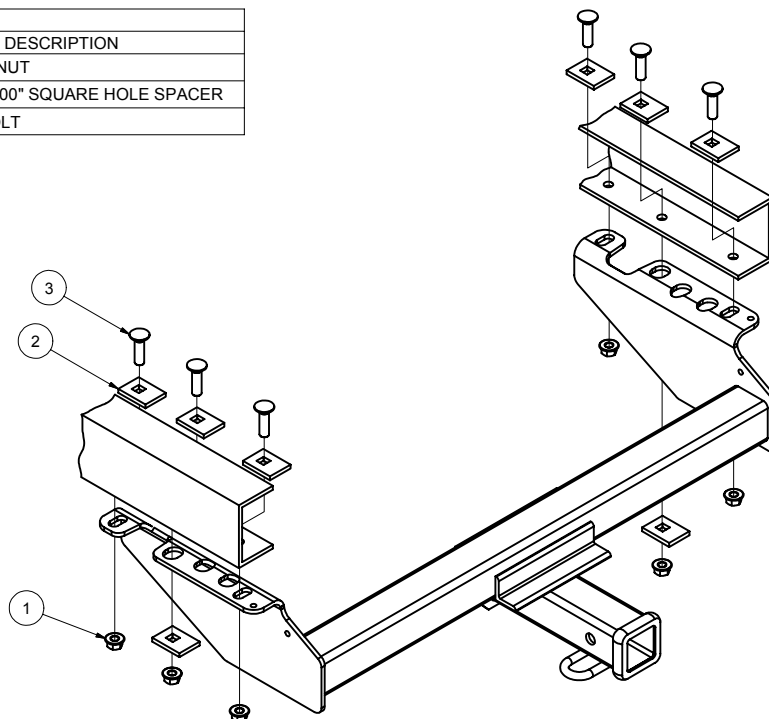

HITCH WEIGHT: 38 LBS.

INSTALL TIME: 45 MINUTES

INSTALL NOTES:

- SOME DRILLING REQUIRED

INSTALLATION STEPS

1973-1997 FORD F-SERIES(EXCEPT 73-79 CREW CAB): LOWER SPARE TIRE:

- (1) USING THE LARGE HOLE IN THE HITCH HANGER AS A GUIDE, PLACE THIS OVER THE STOCK RIVET ON EACH SIDE OF THE FRAME. CENTER THE HITCH ON THE FRAME AND MARK THE SIX HOLES WHICH MUST BE DRILLED.
- (2) USING THE STEP METHOD OF DRILLING, WHICH IS DRILLING A 1/8" PILOT HOLE, THEN DRILLING A 3/8" HOLE AND FINISHING WITH A 1/2" HOLE, DRILL THE SIX 1/2" MOUNTING HOLES. IN EACH HOLE PLACE A 1/2" x 2" CARRIAGE BOLT AND SPACER THROUGH THE FRAME. RAISE THE HITCH INTO POSITION AND SECURE EACH BOLT WITH A 1/2" FLANGE NUT.
- (3) NOTE: THAT ON SOME MODELS THE 9/16" SLOTS IN THE HITCH HANGERS WILL LINE UP WITH THE SMALL 1/4" HOLES IN THE VEHICLE FRAME. IF THIS IS THE CASE DRILL THESE HOLES OUT TO 1/2".

1978-1997 FORD BRONCO FULL SIZE:

NOTE: THE BUMPER BOLTS CAN BE LOOSENED AND THE BUMPER RAISED TO INCREASE CLEARANCE FOR THE HITCH. RE-TIGHTEN BOLTS.

- (1) USING THE LARGEST HOLE IN THE HITCH HANGER AS A GUIDE, PLACE THIS HOLE OVER THE STOCK RIVET ON EACH SIDE OF THE FRAME. CENTER THE HITCH ON THE FRAME AND MARK THE SIX HOLES TO BE DRILLED.
- (2) DRILL THE SIX 1/2" HOLES, TAKE EXTRA CARE AROUND THE GAS TANK.
- (3) A 1/2" CARRIAGE BOLT AND SPACER MUST BE PLACED IN EACH HOLE. BECAUSE OF THE TIGHT CLEARANCE WITH THE GAS TANK THE TWO FORWARD HOLES ON EACH SIDE MUST BE FISHWIRED. THIS IS DONE BY WRAPPING A THIN WIRE AROUND THE END OF THE BOLT AND THROUGH THE SQUARE HOLE SPACER. USE THE ACCESS HOLE IN THE CROSSMEMBER NEXT TO THE FRAME, TO FEED THE BOLTS THROUGH.
- (4) RAISE THE HITCH BACK INTO POSITION AND SECURE EACH BOLT WITH A 1/2" FLANGE NUT.

1967-2002 DODGE FULL SIZE:

NOTE: IF THE BUMPER INTERFERES WITH THE RECEIVER HITCH, LOOSEN THE BUMPER BRACKETS AND REPOSITION UPWARD. RE-TIGHTEN.
MOUNTING LOCATIONS MAY NEED TO BE DRILLED ON SOME VEHICLES.

- (1) AT THE REAR OF THE FRAME FIND THE 1/2" ROUND HOLES.
- (2) IN THE FIRST AND THIRD 1/2" ROUND HOLES PLACE A 1/2" CARRIAGE BOLT AND SPACER DOWN THROUGH THE FRAME.
- (3) RAISE THE HITCH INTO POSITION, SECURE WITH A 1/2" FLANGE NUT ON EACH BOLT, HAND TIGHTEN ONLY.
- (4) CENTER THE HITCH AND USE AS A TEMPLATE TO DRILL THE FOUR REMAINING HOLES TO 1/2" DIAMETER.
- (5) PLACE A 1/2" x 2" CARRIAGE BOLT AND SPACER IN ALL MOUNTING HOLES, AND SECURE WITH A 1/2" FLANGE NUT.

ALL MODELS:

DUE TO THE LARGE SIZE OF THE MIDDLE MOUNTING HOLE, A SPACER MUST BE PLACED BETWEEN THE HITCH AND THE FLANGE NUT AT THAT LOCATION (BOTH SIDES). COMPLETE INSTALLATION BY TIGHTENING ALL HARDWARE TO 75 FT LBS WITH A TORQUE WRENCH. REPOSITION SPARE TIRE IF NECESSARY.

PERIODICALLY CHECK THIS RECEIVER HITCH TO ENSURE THAT ALL FASTENERS ARE TIGHT AND THAT ALL STRUCTURAL COMPONENTS ARE SOUND.

Curt Manufacturing Inc., warrants this product to be free of defects in material and/or workmanship at the time of retail purchase by the original purchaser. If the product is found to be defective, Curt Manufacturing Inc., may repair or replace the product, at their option, when the product is returned, prepaid, with proof of purchase. Alteration to, misuse of, or improper installation of this product voids the warranty. Curt Manufacturing Inc.'s liability is limited to repair or replacement of products found to be defective, and specifically excludes liability for incidental or consequential loss or damage.