



**11808**

**SAAB 900**

11/2/2006

**GROSS LOAD CAPACITY WHEN USED AS A WEIGHT CARRYING HITCH: 2,500 LBS. TRAILER WEIGHT & 200 LBS. TONGUE WEIGHT. \*\*\*DO NOT EXCEED VEHICLE MANUFACTURER'S RECOMMENDED TOWING CAPACITY.\*\*\***

Parts List			
ITEM	QTY	PART NUMBER	DESCRIPTION
1	1	CM-SP103	NUT PLATE
2	2	3/8 - 16 x 1 1/4	HEX BOLT
3	2	3/8"	LOCK WASHER
4	2	3/8"	WASHER
5	2	M10 - 1.5 x 30 HEX	HEX BOLT
6	2	7/16	HELICAL LOCK WASHER
7	2	M - M10 x 1.5	Hex Nut
8	1	D-55001	1 1/4" CURT BALL MOUNT
9	1	F-4	1/2" DIA. PIN & CLIP

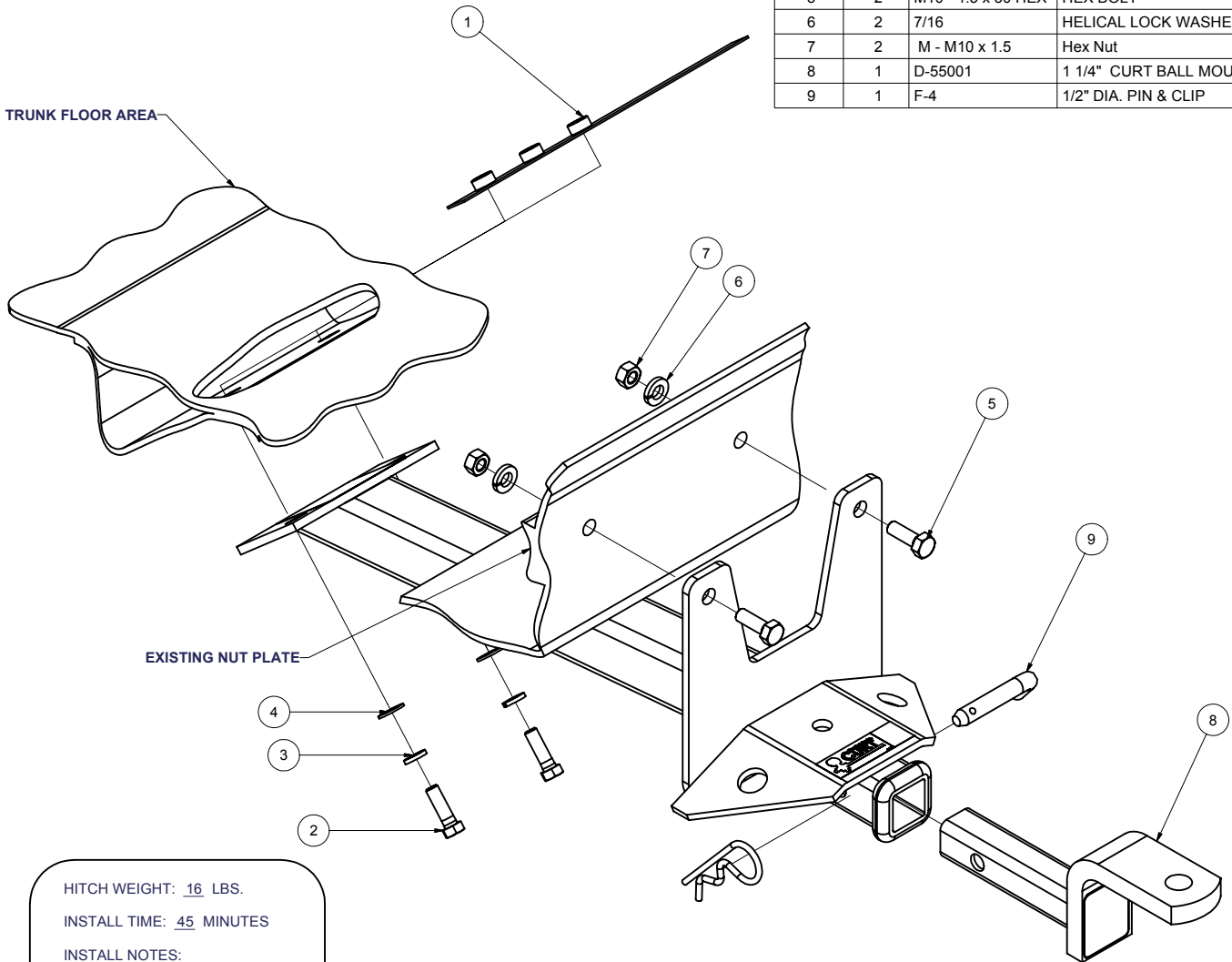

HITCH WEIGHT: 16 LBS.  
 INSTALL TIME: 45 MINUTES  
 INSTALL NOTES:  
**NO DRILLING REQUIRED**

**INSTALLATION STEPS**

- 1) Remove two existing 10mm screws at either side of the Saab rear bumper bracket at the rear panel. On certain models it will be necessary to remove a bolted on bracket under the floor at the rear center of the car.
- 2) Using fasteners as shown, mount the hitch to the car at the rear panel. Using fasteners and nut plate provided, mount the hitch at the existing Saab bracket under the floor.
- 3) Torque all 10mm fasteners to 36 lb-ft, and all 3/8" fasteners to 35 lb-ft.

**PERIODICALLY CHECK THIS RECEIVER HITCH TO ENSURE THAT ALL FASTENERS ARE TIGHT AND THAT ALL STRUCTURAL COMPONENTS ARE SOUND.**

Curt Manufacturing Inc., warrants this product to be free of defects in material and/or workmanship at the time of retail purchase by the original purchaser. If the product is found to be defective, Curt Manufacturing Inc., may repair or replace the product, at their option, when the product is returned, prepaid, with proof of purchase. Alteration to, misuse of, or improper installation of this product voids the warranty. Curt Manufacturing Inc.'s liability is limited to repair or replacement of products found to be defective, and specifically excludes liability for incidental or consequential loss or damage.